

# 3-PC BALL VALVE

三片式球阀

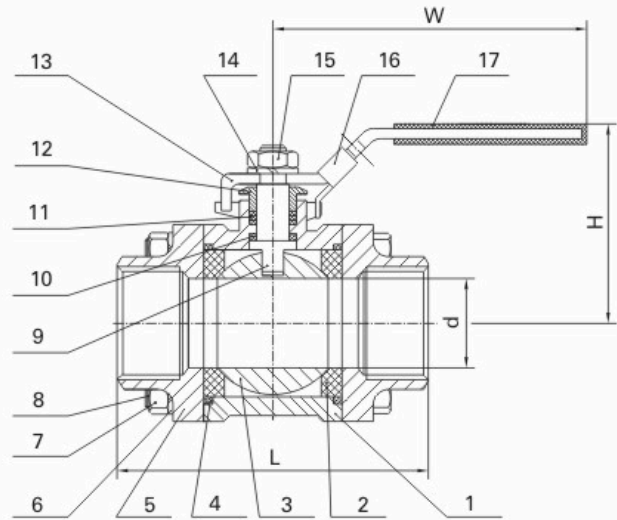

## MV-31

- 螺纹标准: ISO, BS, DIN, JIS, ASME
- 公称压力: 1000PSI (PN63)
- 工作温度: -25°C~+ 180°C
- 材 料: CF8M, CF8, CF3M, WCB
  
- Investment casting for body and cap
- Full bore
- Thread: ISO, BS, DIN, JIS, ASME
- Pressure rating: 1000PSI (PN63)
- Working temperature: -25°C~+ 180°C
- Material: CF8M, CF8, CF3M, WCB

## MATERIAL LIST

ITEM	PART	MATERIAL	QTY.
1	Body	CF8M	1
2	Ball Seat	R-PTFE(15%)	2
3	Ball	SS316	1
4	Body Gasket	PTFE	2
5	Cap	CF8M	2
6	Spring Washer	SS304	4(12)
7	Nut	SS304	4(12)
8	Bolt	SS304	4(6)
9	Stem	SS316	1
10	Thrust Washer	PTFE	1
11	Stem Packing	PTFE	1
12	Gland Nut	SS304	1
13	Handle	SS304	1
14	Spring Washer	SS304	1
15	Nut	SS304	1
16	Lock Device	SS304	1
17	Handle Cover	PLASTIC	1

PRESSURE-TEMPERATURE RATING

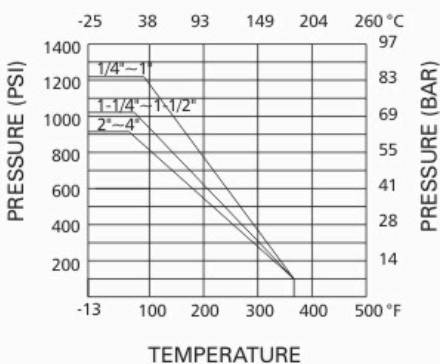

## DIMENSION LIST (Threads)

SIZE	d	L		H	W	N·m	Kgs
		BSP	NPT				
1/4"	11	48	51	51	105	4	0.35
3/8"	12.5	48	51	51	105	4	0.34
1/2"	15	54	53	53	118	5	0.39
3/4"	20	73	60	60	118	8	0.73
1"	25	80	75	75	150	10	1.10
1-1/4"	32	90	80	80	150	14	1.60
1-1/2"	40	102	88	88	182	18	2.52
2"	50	118	95	95	182	25	3.32
2-1/2"	65	151	141	121	254	48	6.50
3"	80	182	172	135	254	75	11.00
4"	100	218	202	158	285	110	19.20