

1-PC BALL VALVE

一片式球阀

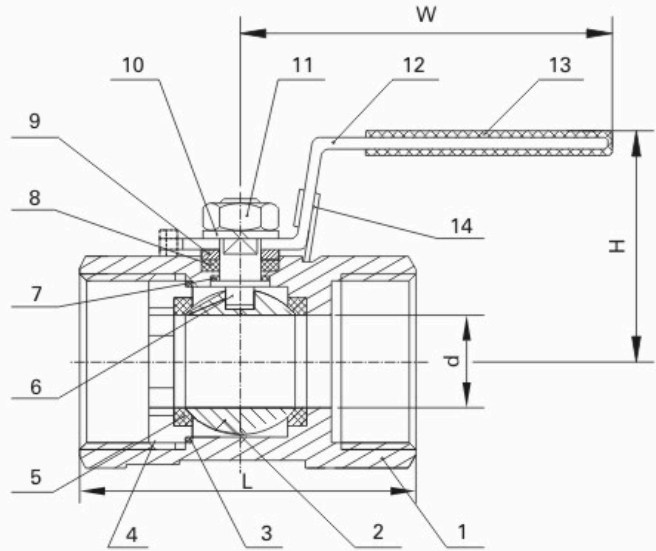

MV-11

- 缩径
- 螺纹标准: ISO, BS, DIN, JIS, ASME
- 公称压力: 1000 PSI (PN63)
- 工作温度: $-25^{\circ}\text{C} \sim +180^{\circ}\text{C}$
- 材 料: CF8M, CF8, CF3M, WCB
- Investment casting for body and cap
- Reduce bore
- Thread: ISO, BS, DIN, JIS, ASME
- Pressure rating: 1000 PSI (PN63)
- Working temperature: $-25^{\circ}\text{C} \sim +180^{\circ}\text{C}$
- Material: CF8M, CF8, CF3M, WCB

MATERIAL LIST

ITEM	PART	MATERIAL	QTY.
1	Body	CF8M	1
2	Ball	SS316	1
3	Body Gasket	PTFE	1
4	Cap	CF8M	1
5	Ball Seat	R-PTFE (15%)	2
6	Stem	SS316	1
7	Thrust Washer	PTFE	1
8	Stem Packing	PTFE	1
9	Washer	SS304	1
10	Spring Washer	SS304	1
11	Nut	SS304	1
12	Handle	SS304	1
13	Handle Cover	PLASTIC	1
14	Lock Device	SS304	1

PRESSURE-TEMPERATURE RATING

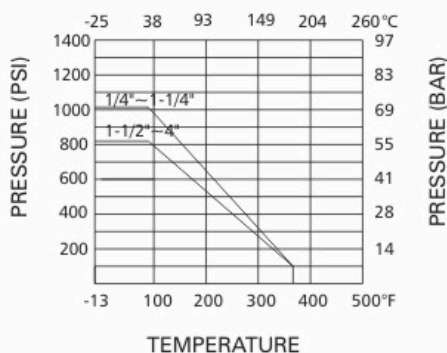

DIMENSION LIST

SIZE	d	L	H	W	N·m	Kgs
1/4"	5	40	32	68	4	0.06
3/8"	7	45	33	68	4	0.09
1/2"	9.5	56	42	95	6	0.15
3/4"	12.5	59	45	95	6	0.22
1"	15	71	48	95	8	0.36
1-1/4"	20	76	58	106	10	0.55
1-1/2"	25	84	67	128	14	0.86
2"	32	99	74	130	18	1.29
2-1/2"	38	120	80	154	35	1.98
3"	50	140	100	191	58	3.60
4"	65	170	129	246	93	7.47