

3-WAY BALL VALVE (Reduce bore)

三通式球阀 (缩径)

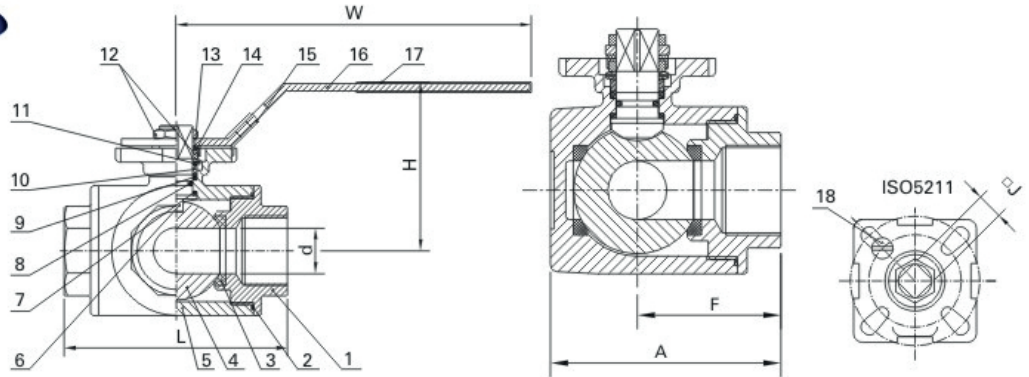

PORT \ TURN	0°	90°	180°	270°
T-BALL				
L-BALL				

MV-85

- 缩径
- 螺纹标准: ISO, BS, DIN, JIS, ASME
- 驱动盘标准: ISO 5211
- 公称压力: PN63 (1000PSI)
- 工作温度: -25°C~+ 180°C
- 材 料: CF8M, CF8, CF3M, WCB
- Investment casting for body and cap
- Reduce bore
- Thread: ISO, BS, DIN, JIS, ASME
- Mounting pad: ISO 5211
- Pressure rating: PN63 (1000PSI)
- Working temperature: -25°C~+ 180°C
- Material: CF8M, CF8, CF3M, WCB

MATERIAL LIST

ITEM	PARTS	MATERIAL	QTY.
1	Cap	CF8M	3
2	Gasket	PTFE	3
3	Ball Seat	R-PTFE(15%)	4
4	Ball	SS316	1
5	Body	CF8M	1
6	Stem	SS316	1
7	Thrust Washer	PTFE	1
8	O-Ring	VITON	1
9	Stem Packing	PTFE	1
10	Stem Ring	SS316	1
11	Belleve Washer	SS301	2
12	Nut	SS304	2
13	Plate Washer	SS304	1
14	Nut Stopper	SS304	1
15	Lock Device	SS304	1
16	Handle	SS304	1
17	Handle Sleeve	PLASTIC	1
18	Stop Pin	SS304	1

PRESSURE-TEMPERATURE RATING

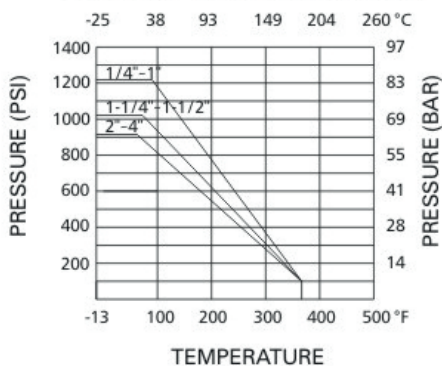

DIMENSION LIST

SIZE	d	L	H	W	F	A	J	ISO5211	N-m	Kgs(L)	Kgs(T)
1/4"	9.5	75	66	130	37.5	57.5	9	F03/F04	8	0.70	0.70
3/8"	11	75	66	130	37.5	57.5	9	F03/F04	8	0.67	0.67
1/2"	12	75	66	130	37.5	57.5	9	F03/F04	8	0.63	0.63
3/4"	15	85	72	161	42.5	65.5	11	F04/F05	9	0.94	0.94
1"	20	100	77	161	50	79	11	F04/F05	15	1.39	1.38
1-1/4"	25	122	92	203	61	97	14	F05/F07	20	2.91	2.89
1-1/2"	32	131	96	203	65.5	106.5	14	F05/F07	30	3.66	3.60
2"	40	158	107	203	79	129	14	F05/F07	45	6.31	6.21
2-1/2"	49	178	135	254	89	145	17	F07/F10	50	8.95	8.72
3"	60	202	147	254	101	167	17	F07/F10	80	13.11	12.81
4"	75	246	160	310	123	203	17	F07/F10	110	22.10	21.60