

1-PC WAFER FLANGE BALL VALVE

一片式对夹德标法兰球阀

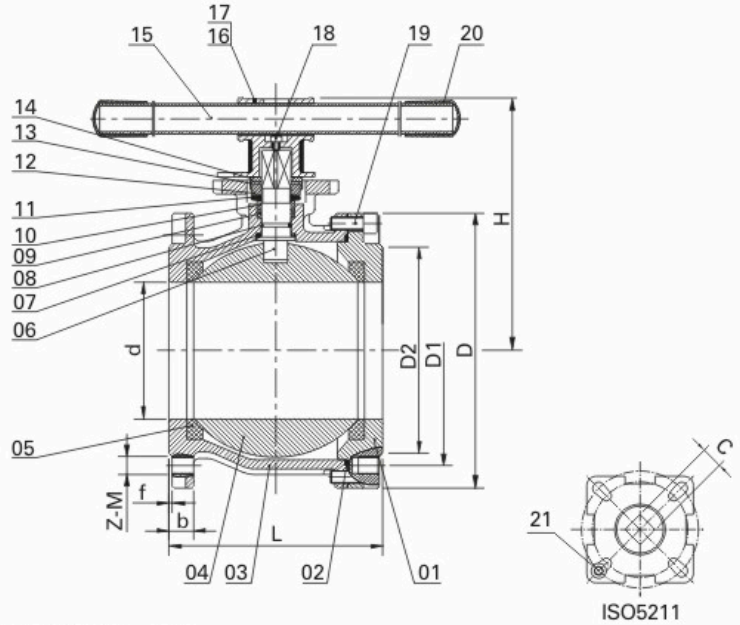

MV-14 (DN125~DN200)

- 法兰标准: DIN2543
- 公称压力: PN16
- 工作温度: -25°C~+180°C
- 材 料: CF8M, CF8, CF3M, WCB
- Investment casting for body and cap
- Flanged ends: DIN2543
- Pressure rating: PN16
- Working temperature: -25°C~+180°C
- Material: CF8M, CF8, CF3M, WCB

MATERIAL LIST

ITEM	PART	MATERIAL	QTY.
1	Cap	CF8M	1
2	Body Gasket	PTFE	1
3	Body	CF8M	1
4	Ball	SS316	1
5	Ball Seat	R-PTFE (15%)	2
6	Stem	SS316	1
7	Thrust Washer	PTFE	1
8	O- Ring	VITON	1
9	Stem Packing	PTFE	1
10	Stem Ring	SS316	1
11	Belleville Washer	SS301	2
12	Nut	SS304	1
13	Nut Stopper	SS304	1
14	Plate Washer	SS304	1
15	Handle	SS304	1
16	Jack Screw	SS304	1
17	Handle Head	CF8	1
18	Handle Bolt	SS304	1
19	Bolt	SS304	8
20	Plastic Cover	PLASTIC	2
21	Stop Pin	SS304	1

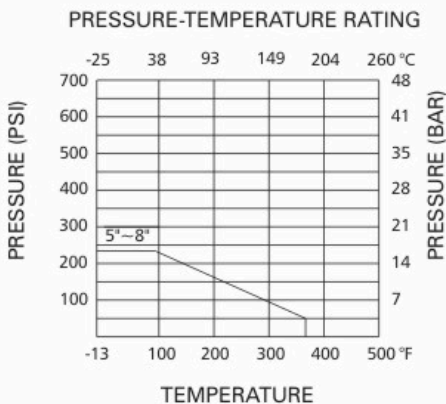

DIMENSION LIST

SIZE	PN	d	L	D	D1	D2	b	f	H	W	C	ISO5211	Z-M	N.m	Kgs
DN125	10/16	125	195	250	210	188	22	3	230	600	22	F10/F12	8-M16	200	37.5
DN150	10/16	150	225	285	240	212	22	3	248	600	22	F10/F12	8-M20	300	61.5
DN200	16	200	275	340	295	268	24	3	300	800	27	F12/F14	12-M20	400	106.0