

1-PC FLANGE BALL VALVE WITH MOUNTING PAD (ANSI)

一片式法兰球阀(带驱动盘)

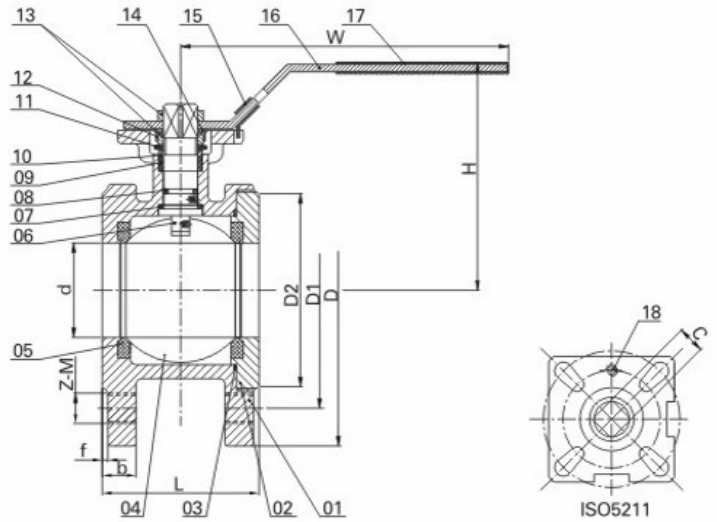

MV-14F

- 防火设计
- 法兰标准: ASME B16.5
- 结构长度: EN558 Series 100
- 驱动盘标准: ISO5211
- 公称压力: 150Lb
- 工作温度: -25°C~+180°C
- 材 料: CF8M, CF8, CF3M, WCB
- Investment casting for body and cap
- Fire-safe design
- Flanged ends: ASME B16.5
- Face to Face: EN558 Series100
- Mounting Pad: ISO5211
- Pressure rating: 150Lb
- Working temperature: -25°C~+ 180°C
- Material: CF8M, CF8, CF3M, WCB

MATERIAL LIST

ITEM	PARTS	MATERIAL	QTY.
1	Body	CF8M	1
2	Cap	CF8M	1
3	Body Gasket	PTFE	1
4	Ball	SS316	1
5	Ball Seat	R-PTFE (15%)	2
6	Stem	SS316	1
7	Thrust Washer	PTFE	1
8	O- Ring	VITON	1
9	Stem Packing	PTFE	1
10	Packing Ring	SS304	1
11	Belleville Washer	SS301	2
12	Nut Stopper	SS304	1
13	Nut	SS304	2
14	Plate Washer	SS304	1
15	Lock Device	SS304	1
16	Handle	SS304	1
17	Plastic Cover	PLASTIC	1
18	Stop Pin	SS304	1

PRESSURE-TEMPERATURE RATING

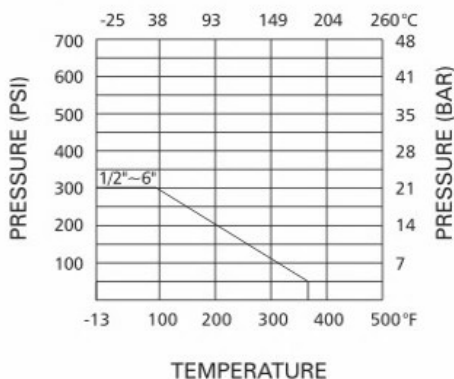

DIMENSION LIST

SIZE	d	L	D	D1	D2	b	f	H	W	C	ISO5211	Z-M	N.m
1/2"	15	35	89	60.5	35	11	2	89	117	9	F03/F04	4-1/2"	5
3/4"	20	39	98	70	43	11	2	94	117	9	F03/F04	4-1/2"	8
1"	25	44	108	79.5	51	12	2	95	164	11	F04/F05	4-1/2"	10
1- 1/4"	32	52	117	89	64	13	2	100	164	11	F04/F05	4-1/2"	14
1-1/2"	40	64	127	98.5	73	15	2	105	203	14	F05/F07	4-1/2"	18
2"	50	83	152	120.5	92	16	2	125	203	14	F05/F07	4-5/8"	25
2-1/2"	65	105	178	139.5	105	18	2	140	255	17	F07/F10	4-5/8"	48
3"	76	121	190	152.5	127	19	2	145	255	17	F07/F10	4-5/8"	75
4"	94	152	229	190.5	157	24	2	175	302	17	F07/F10	8-5/8"	110
5"	125	196	254	216	186	24	2	228	600	22	F10/F12	8-3/4"	300
6"	150	236	279	241.5	216	26	2	246	600	22	F10/F12	8-3/4"	300
8"	200	315	343	298.5	270	29	2	300	800	27	F12/F14	8-3/4"	400